

WHISPERTM

FLAT SCREEN TV LIFT

Ride



Rack & Pinion design with unique patent pending stability system

Uses German Bosch motor for reliable & quiet operation

Requires only 2-3/4" (70mm) depth behind the TV

200 Lb. weight capacity

29.5" (750mm) Stroke

Simple & fast mounting

Very competitive pricing



Whisper-Ride is delivered complete inside one carton and includes:

Remote control (RF)

Manual push switch

Adjustable lid lifter

Universal TV mounting bracket

Part No. 4050.845.060



WoodTM Technology

*Innovative Products, Ideas and Solutions
for Furniture and Cabinet Manufacturing*

P.O. Box 1301 ▪ 225 Elf Way ▪ Pittsboro, NC 27312

Ph: 800-231-9522 ▪ 919-542-6300 ▪ Fax: 919-542-2727

www.woodtechnology.com

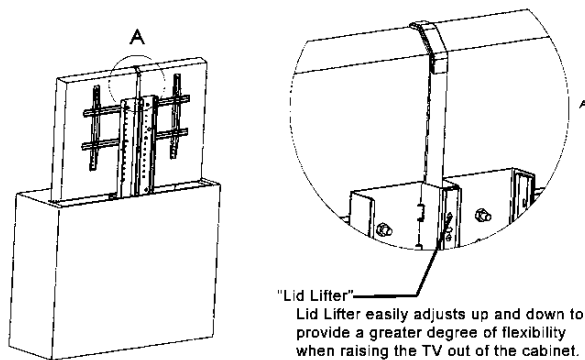
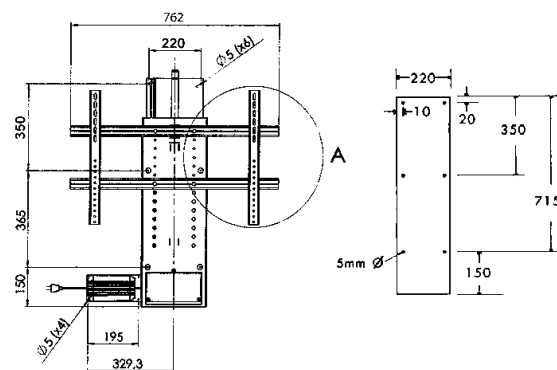
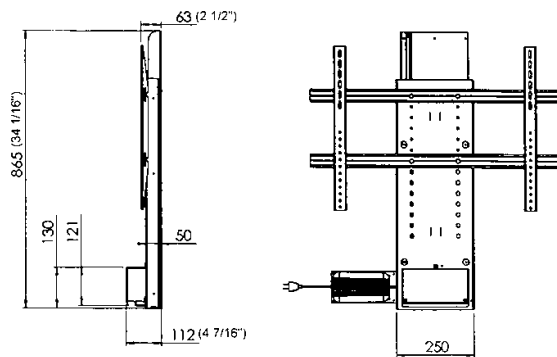

"Lid Lifter"
Lid Lifter easily adjusts up and down to provide a greater degree of flexibility when raising the TV out of the cabinet.



UL US
LISTED
Electrical Power Supply

Whisper-Ride was designed and developed by Wood Technology, Inc. and the Danish firm ConSet with these basic principles in mind; Quality, reliability, simplicity, affordability, design and function. With the installer and consumer in mind the unit can be fitted inside a cabinet or against any suitable surface within minutes by simply screwing in the TV lift unit, power supply and RF module. Once you make a few simple connections and position the universal mounting brackets the TV is ready to be secured. Mounting can also be reversed to allow Whisper-Ride to drop down. With Wood Technology's 30 year experience and ConSet's engineering expertise it's a perfect fit for flat screen TV's up to 50 inches. Please note that due to the 29.5" (750mm) stroke some 50" models may not be suitable.

Wood™
Technology

*Innovative Products, Ideas and Solutions
for Furniture and Cabinet Manufacturing*

P.O. Box 1301 ▪ 225 Elf Way ▪ Pittsboro, NC 27312
Ph: 800-231-9522 ▪ 919-542-6300 ▪ Fax: 919-542-2727
www.woodtechnology.com